



## CANlink 713/714: CAN Bus Displays

# Rugged, Modern + Functional Value

These 5- and 7-inch CAN bus displays feature vibrant color and an economical, minimalistic design for an updated look and feel and offer programming options such as Crank, Qt and CODESYS.

### Built Tough

Made for harsh environments, these displays offer an updated interface and can be mounted in the cab or outside your vehicle.

### Modern Technology

Sunlight readable color LCD display with 800x480 resolution and optional PCAP touchscreen or pushbuttons for easy navigation and control.

### Value + Function

Featuring a premium edge-to-edge glass design at an economical price point. Configured with optional I/O to help reduce the cost of the control architecture.



IP67 sealed



Touchscreen with gloves & in rain



Ultra-wide viewing angles



Shock & Vibration Resistant



Sunlight readable



-40C to +65C

# CANlink 713 / 714 Display | Specifications

COMPUTING CORE	
<b>Overview</b>	Cortex-A7 ARM Processor running at 800 MHz
<b>CPU</b>	Cortex A7 @ 800 MHz (single-core)
<b>Graphics Acceleration</b>	Pixel Processing Pipeline (PXP) to support 2D image processing
<b>Flash</b>	8GB eMMC Flash
<b>RAM</b>	512MB DDR3 RAM

DISPLAY	
<b>Type</b>	IPS TFT with >85° viewing angles in all directions
<b>Cover Lens</b>	Hardened Glass with AR coating
<b>Optical Bonding</b>	LCD Optically bonded to hardened AR glass lens for enhanced sunlight readability
<b>Size &amp; Resolution</b>	5" & 7", 800x480 pixel resolution, 16:9 aspect ratio
<b>Color Depth</b>	24-bit, 16.7 million
<b>Contrast Ratio</b>	1000:1 (typ)
<b>Brightness</b>	CL-713: 800 cd/m2 (nits) CL-714: 1000 cd/m2 (nits)
<b>Dimming</b>	Standard in 0.1% increments 0-100%
<b>Ambient Light Sensor</b>	Standard, available for automatic dimming

HMI	
<b>Touchscreen</b>	Optional. Projected Capacitive (PCAP) calibrated for use with heavy gloves and wet environments.
<b>Real Time Clock</b>	Yes- with internal battery (15 year life- typical) Displays date and time plus periodic wake-up to perform tasks without human interaction

ELECTRICAL	
<b>Operating Voltage</b>	6 - 32 VDC
<b>Key Switch</b>	Standard for Start/Shutdown, Suspend/Resume
<b>Inputs</b>	up to 11 inputs (see page 3 for details)
<b>Outputs</b>	up to 4 outputs (see page 3 for details)
<b>Conducted Transient Immunity</b>	ISO 7637-2, Pulse 1, 2a, 2b, 3a, 3b
<b>Starting Profile</b>	ISO 16750-2, Section 4.6.3
<b>Load Dump</b>	ISO 16750-2, Section 4.6.4, 40V clamped

MECHANICAL	
<b>Buttons</b>	Optional buttons available
<b>Housing Material</b>	PC-ABS Plastic with Aluminum Heatsink (back cover)
<b>Installation</b>	Panel or RAM mount (see dimensional drawings)
<b>Connectors</b>	1x 18-pin Deutsch DT for Power, CAN, I/O 4x M12 for USB-A, 4-Wire Ethernet, Video 1, Video 2
<b>Dimensions (mm)</b>	CL-713 (Buttons): 146.8 x 142.4 x 42.6 CL-713 (No-Buttons): 146.8 x 110.2 X 42.6 CL-714 (Buttons): 193.3 x 169.7 x 46.0 CL-714 (No-Buttons): 193.3 x 137.7 x 46.0
<b>Weight (g)</b>	CL-713 (Buttons): 1.10 lbs CL-713 (No-Buttons): 0.95 lbs CL-714 (Buttons): 2.00 lbs CL-714 (No-Buttons): 1.75 lbs

INTERFACES	
<b>CAN</b>	2x CAN ports
<b>USB</b>	1x USB OTG (capable of supplying up to 500mA to device)
<b>Ethernet</b>	1x Ethernet 10/100 Base-T
<b>Video</b>	2x Analog Video Inputs, NTSC or PAL (1x active at a time)

OPERATING SYSTEM	
<b>System</b>	Custom Linux system
<b>Kernel</b>	Linux Kernel 5.4 (Long Term Support) u-boot 2022.02.1 Buildroot: 2020.08.1
<b>BSP</b>	Available to create a custom Linux image
<b>Bootup Time</b>	Cold boot ~10-16 seconds

ENVIRONMENTAL SPECIFICATIONS	
<b>IP Class</b>	IP67
<b>Regulatory Compliance</b>	CE Marked
<b>EMC Conformity</b>	FCC Part 15 (b) and ISED Canada. 2014/30/EU – CE Mark Radiated Emissions: ISO 13766-1, EN 13309, ISO 14982 Conducted Emissions: CISPR 25, Section 6.3 (Voltage Method) Radiated Immunity: ISO 11452-2 Conducted Immunity: ISO 11452-4 (BCI method), 20-200MHz at 100mA ESD: ISO 10605, IEC 61000-4-2
<b>Vibrations</b>	IEC 60068-2-64 Random Vibration Test VII Test: Random Vibe, Freq. Range: 10-2000Hz, Level: 57.9m/s2 per Figure 11 / Table 12 Duration/axis: 8hrs (32Hrs total exposure)
<b>Shock</b>	IEC 60068-2-27 Mechanical Shock Level: 500 m/s2- 6ms, Shape: Half-sinusoidal # Pulses: 100 per direction/axis (600 total shock pulses) Level: 500 m/s2- 11ms, Shape: Half-sinusoidal # Pulses: 6,000 per direction/axis (18,000 total shock pulses)
<b>Temperature Range</b>	Operating: -40C to +65C Storage: -40C to +80C

SOFTWARE FRAMEWORK & TOOLS	
<b>Development Environment</b>	Virtual machine or Native Linux
<b>Programming</b>	Supported languages include C++, C (GCC Compiler), QML, JavaScript, Python, HTML5, Rust
<b>UI Frameworks</b>	The Container based environment allows for easy selection of your desired UI development tool if it is not one of our currently offered solutions: * Qt 5.15 * Crank 7.x * CODESYS 3.5 * Web framework support (contact HED for details)
<b>CAN Networking</b>	Configurable for J1939 and CANopen networks



# CANlink 713 / 714 Display | Pinouts

CONNECTOR A - 18 PIN DEUTSCH		
	Base Configuration	Full IO Configuration
Pin 1	Output DOUT(-)(0.5A) / PWM(-)(0.5A)	Output DOUT(+)(2A) / PWM(+)/ECC/(+)(2A) / Input STB/STG
Pin 2	N/A	Output DOUT(+)(2A) / PWM(+)/ECC/(+)(2A) / Input STB/STG
Pin 3	N/A	Output DOUT(+)(2A) / PWM(+)/ECC/(+)(2A) / Input STB/STG
Pin 4	N/A	Output DOUT(+)(2A) / PWM(+)/ECC/(+)(2A) / Input STB/STG
Pin 5	Battery (-)	Battery(-)
Pin 6	Unswitched Battery (+) / Input Battery Voltage	Unswitched Battery(+)** / Input Battery Voltage
Pin 7	CAN1-H	CAN1-H
Pin 8	CAN1-L	CAN1-L
Pin 9	N/A	Input STB/STG/VTD(0-5.8V)/FREQ/PWM/Encoder(1A) / RTD(0-500ohm)
Pin 10	N/A	Input STB/STG/VTD(0-5.8V)/FREQ/PWM/Encoder(1B) / RTD(0-2Kohm)
Pin 11	Input STB Wake-up (Key Switch)	Input STB Wake-Up (Key Switch)
Pin 12	Input STB/STG/VTD (0-5.8V)	Input STB/STG/VTD(0-5.8V)
Pin 13	CAN2-L	CAN2-L
Pin 14	CAN2-H	CAN2-H
Pin 15	N/A	Input STB/STG/VTD(0-5.8V)/FREQ/PWM/Encoder(2A) / RTD(0-500ohm)
Pin 16	N/A	Input STB/STG/VTD(0-5.8V)/FREQ/PWM/Encoder(2B) / RTD(0-2Kohm)
Pin 17	N/A	5VDC Sensor Supply Ground / Input Supply Ground Voltage / Input STB/STG/VTD(0-5.8V)
Pin 18	N/A	5VDC Sensor Supply (250mA) / Input Supply Voltage / Input STB/STG/VTD(0-5.8V)

\*\*Unswitched vehicle battery must be connected for controlled shutdown to properly store any data to memory, and for Sleep and Wake-Up to function properly.

WIRE ETHERNET CONNECTOR: M12 (D-Key)	
Pin 1	TXP
Pin 2	RXP
Pin 3	TXN
Pin 4	RXN

USB OTC CONNECTOR: M12 (A-Key)	
Pin 1	USB (Power)
Pin 2	USB (DM)
Pin 3	USB (DP)
Pin 4	USB (Ground)
Pin 5	USB (OTG)

MATING CONNECTOR - DEUTSCH	
DEUTSCH	DT16-18SA-K004
Socket	(16-18) AWG-0462-201-16141 (14-16) AWG-0462-209-16141
Sealing Plug	Non-locking: 114017 Locking: 0413-217-1605
Note: Unused pins required to be sealed to maintain module sealing	

VIDEO CONNECTOR 1: M12 (B-Key)	
Pin 1	Video #1 Signal
Pin 2	Video #1 Ground
Pin 3	+Battery (s/w controlled)
Pin 4	Ground

VIDEO CONNECTOR 2: M12 (B-Key)	
Pin 1	Video #2 Signal
Pin 2	Video #2 Ground
Pin 3	+Battery (s/w controlled)
Pin 4	Ground

MATING CONNECTOR - M12
RAMCO M12 4 & 8 pin Female (for USB, Video) or generic

## Part Number Configuration Options

CL-GGG-TTT-FF-XYZ

PART NUMBER	(GGG) Size		(TTT) I/O Configuration			(FF) Programming				(X) Buttons		(Y) Touchscreen		(Z) Future Options
	713	714	101	102	103	60	70	80	A0	0	1	0	1	1
Description	5"	7"	Inputs 1	≤ 11	≤ 11	Open	Crank	CODESYS	Qt	No	Yes	No	Yes	Reserved for future options
			Outputs 1 (sinking)	4 (sourcing)	4 (sourcing)									
			5VDC Sensor Supply 0	1	1									
			Video Inputs 0	0	2									



# CANlink 713 / 714 Display | Dimensions

## CL-713 Dimensions + Mounting Details

### CL-713-100-XX-0XX NO-BUTTON VERSION

NOTE: THE WIDTH, DEPTH, AND HOLE PATTERNS ARE THE SAME FOR BOTH VERSIONS OF THE DISPLAY.

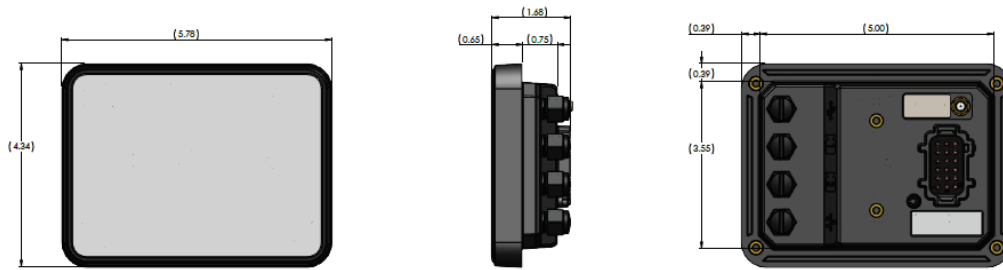

#### Mounting Details:

- Use size M4-07 fasteners in all locations (6X)
- Torque to 20-27 in-lbs
- Fasteners should have max depth of 5.5mm (0.216")
- Recommend using a thread locking patch
- Do **not** use liquid thread locker

### CL-713-100-XX-1XX BUTTON VERSION

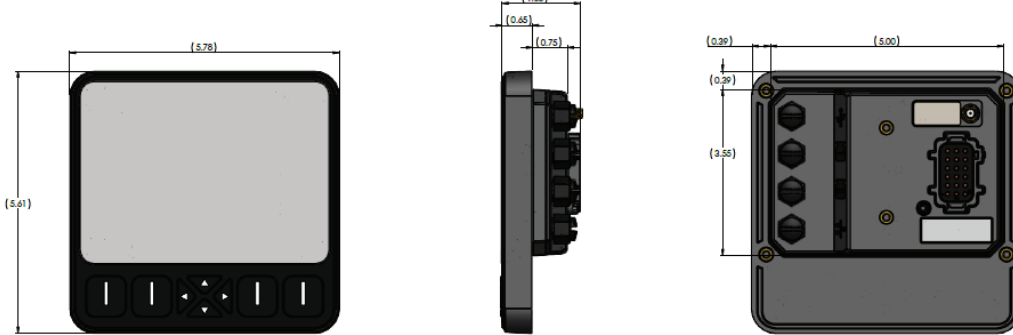

#### RAM Mount Option:

- National Products, Inc.
- [www.rammount.com](http://www.rammount.com)
- Part Number: RAM-B-238U

## CL-714 Dimensions + Mounting Details

### CL-714-100-XX-0XX NO-BUTTON VERSION

NOTE: THE WIDTH, DEPTH, AND HOLE PATTERNS ARE THE SAME FOR BOTH VERSIONS OF THE DISPLAY.

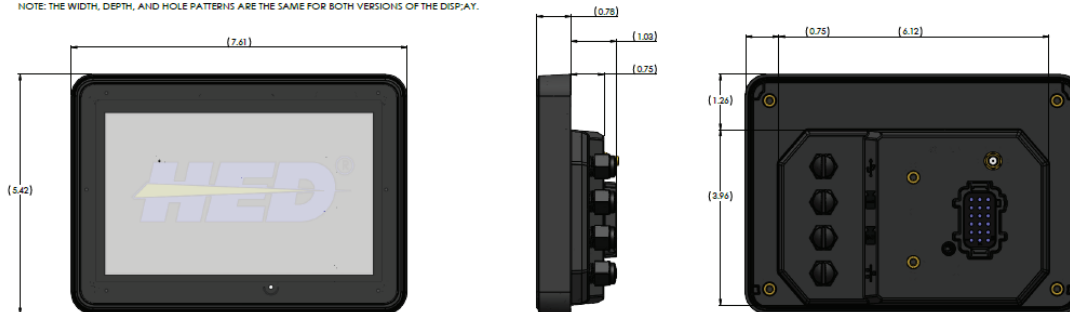

#### Mounting Details:

- Use size M4-07 fasteners in all locations (6X)
- Torque to 20-27 in-lbs
- Fasteners should have max depth of 5.5mm (0.216")
- Recommend using a thread locking patch
- Do **not** use liquid thread locker

### CL-714-100-XX-1XX BUTTON VERSION

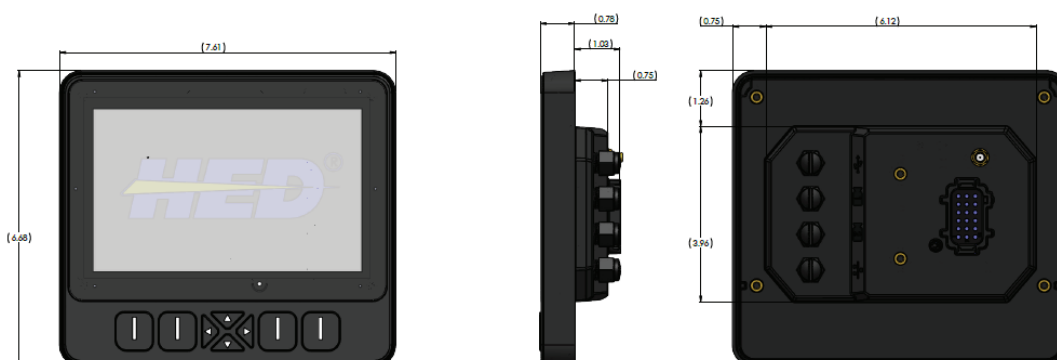

#### RAM Mount Option:

- National Products, Inc.
- [www.rammount.com](http://www.rammount.com)
- Part Number: RAM-B-238U

