

CANLink® CL-709-100-XX Display

4.3in Color Display (Full I/O)

CL-709-100-10 : Master

CL-709-100-20 : Client



The CL-709 is a solid-state Freescale Spectrum microcontroller based display and member of the HED® CANLink® multiplexed control family. Delivered in a plastic enclosure, this unit provides communication messages to the end-user.

The CL-709 is designed for use as a stand alone unit or as part of a distributed system.

The HED® CL-709 can be programmed using HED®'s do-it-yourself CANLink® Arranger™ programming tool or directly by HED® engineering. The Spectrum processor design allows for immediate CAN communication on power-up for communication with other CAN modules in the system.

Features:

- Programmable using Presto™ tool. Ladder Logic not supported.
- Sealed enclosure for external mounting (panel & RAM mount capable)
- Sunlight readable 4.3" TFT Color LCD display
- WQVGA 480x272 pixel format
- LED Backlight with 500 cd/m² (nits) brightness
- Freescale Spectrum controller for CAN and I/O
- 16MB FLASH for graphics, 1MB FLASH for logic, 48KB RAM
- Real Time Clock with Internal Battery
- Navigation Key (4 button)
- Low Power Sleep Mode with Wake-Up by following methods: Digital Input on Connector, CAN Traffic, Time set by software using Real Time Clock

I/O Available:

- (1) USB port (allows software updates directly from USB memory device)
 - FAT32 USB memory device supported (not NTFS)
- (2) J1939 CAN ports
- (1) 5V Sensor Supply
- (1) Wake-Up pin (STB) or input software configurable as switch to battery or switch to ground
- (1) input software configurable as switch to battery or switch to ground
- (4) inputs software configurable as switch to battery, witch to ground, analog, RTD, Frequency, PWM or Encoder
- (4) 2A PWM Outputs w/ Estimated Current Feedback or 3A Digital Outputs or software configurable as switch to battery or ground

Specifications	
Enclosure:	Plastic molded enclosure.
Mating Connectors: Deutsch (I/O)	DT16-18SA-K004 0462-201-16141 (socket for 16-18 AWG wire) 0462-209-16141 (socket for 14-16 AWG wire) 114017 Sealing Plug 0413-217-1605 Locking Sealing Plug Note: Unused pins require plugs to maintain module sealing
RAMCO (USB)	PLM-V84A (USB: M8 4-pin Male Connector) (or other manufacture of IP67 sealed M8 connector)
Operating Voltage:	8 to 32 VDC
Operating Temperature:	-40°C to 70°C * Graphic updates are slower for first 5 minutes if cold start at temperatures below -30°C.
Storage Temperature:	-40°C to 80°C
IP Rating:	IP67 (with M8 sealing cap installed)
PC Boards:	Printed circuit boards are designed for high EMI/RFI protection. The boards are conformal coated with a silicone coating for further water/moisture protection.

Deutsch 18-Pin DT	
Pin	Function
1	Output #1 DOUT(+)(3A) / PWM(+)/ECC/(+)(2A) / STB/STG
2	Output #2 DOUT(+)(3A) / PWM(+)/ECC/(+)(2A) / STB/STG
3	Output #3 DOUT(+)(3A) / PWM(+)/ECC/(+)(2A) / STB/STG
4	Output #4 DOUT(+)(3A) / PWM(+)/ECC/(+)(2A) / STB/STG
5	BAT(-) Module
6	Unswitched +Battery** Module and Outputs / Input #9 Battery Voltage (0-32.5V)
7	CAN1-H
8	CAN1-L
9	5VDC Sensor Supply Ground / Input #8 5V Sensor Supply Gnd (0-6V)
10	5VDC Sensor Supply / Input #7 5V Sensor Supply Voltage (0-6V)
11	Wake-Up (STB Input) / Input #6 STB/STG
12	Input #5 STB/STG
13	CAN2-L
14	CAN2-H
15	Input #4 STB/STG/VTD(0-5.5V)/RTD(0-2Kohm)/FREQ/PWM/Encoder(1A)
16	Input #3 STB/STG/VTD(0-5.5V)/RTD(0-2Kohm)/FREQ/PWM/Encoder(1B)
17	Input #2 STB/STG/VTD(0-5.5V)/RTD(0-500ohm)/FREQ/PWM/Encoder(2A)
18	Input #1 STB/STG/VTD(0-5.5V)/RTD(0-500ohm)/FREQ/PWM/Encoder(2B)

Note: Above pinout is for HED® part number CL-709-100-XX.
Additional part number data sheets may be available on HED® website.

**Unswitched vehicle battery must be connected for controlled shutdown and to properly store data to EEPROM. Display will draw <1mA after turning itself off.

USB Connector (M8)	
Pin	Function
1	USB (Power)
2	USB (DP)
3	USB (DM)
4	USB (Ground)

USB Seal Cap Torque:

20 oz-in

Note: If removing cap to program, cap and rubber washer must be re-installed to above torque to maintain IP67 seal.

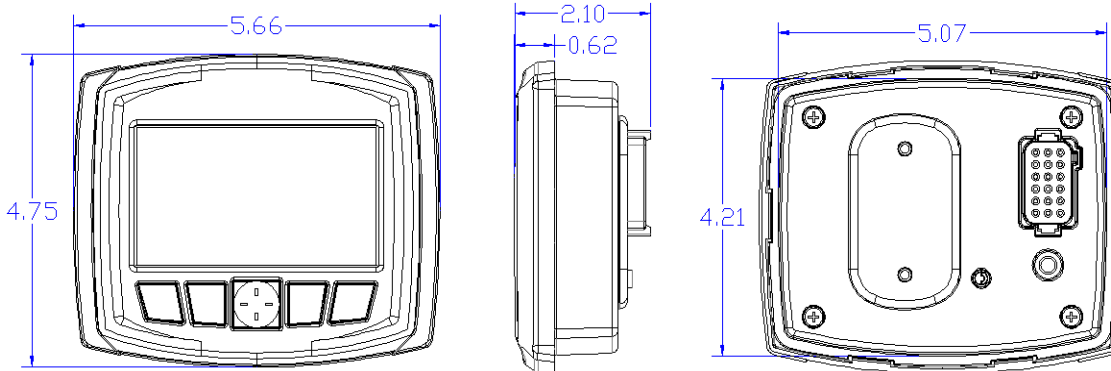

Button Press Inputs	
Button #	Input #
1 (left button)	Input #22 STG
2	Input #23 STG
3	Input #24 STG
4	Input #25 STG
Nav Key (Left)	Input #26 STG
Nav Key (Right)	Input #27 STG
Nav Key (Top)	Input #28 STG
Nav Key (Bottom)	Input #29 STG

Real Time Clock (RTC)		
Item	Composer Input #	Valid Range
Year	Input #10 VTD (0-5000mV)	0 – 255 (1900–2155)
Month	Input #11 VTD (0-5000mV)	0 – 11
Day of Month	Input #12 VTD (0-5000mV)	1 – 31
Day of Week	Input #13 VTD (0-5000mV)	0 – 6
Hour	Input #14 VTD (0-5000mV)	0 – 23
Minute	Input #15 VTD (0-5000mV)	0 – 59
Second	Input #16 VTD (0-5000mV)	0 – 59

LCD and Button Backlights		
Function	Composer Output #	Recommended Frequency
LCD	Output #5 DOUT(+)/PWM(+)	6 kHz
Button	Output #6 DOUT(+)/PWM(+)	250 Hz

RAM Mount option:

National Products, Inc.
www.rammount.com
Part Number: RAM-B-238U

Use size 8-32 fasteners, with max depth of 0.340", and min depth of 0.250" into display.

Torque to 15-20 in-lbs